

**DETAIL 2**  
SCALE 1 : 4  
4 PLACES

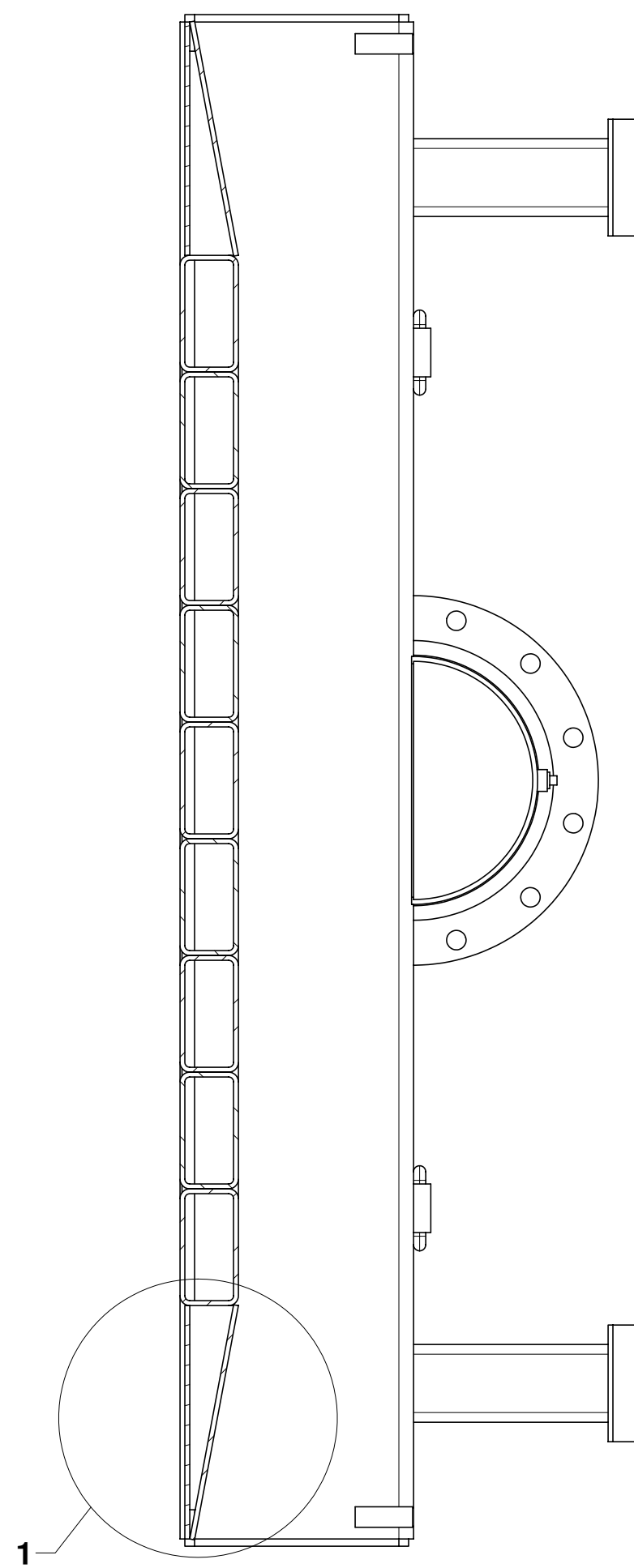

**SECTION B-B**

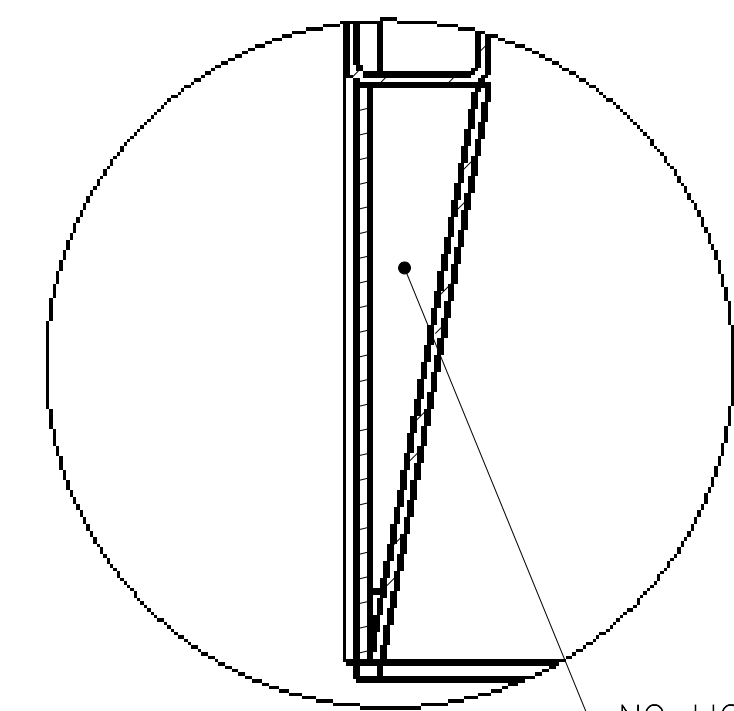

**DETAIL 1**  
SCALE 1 : 4  
ANGLE/FLAT BAR WELDMENT

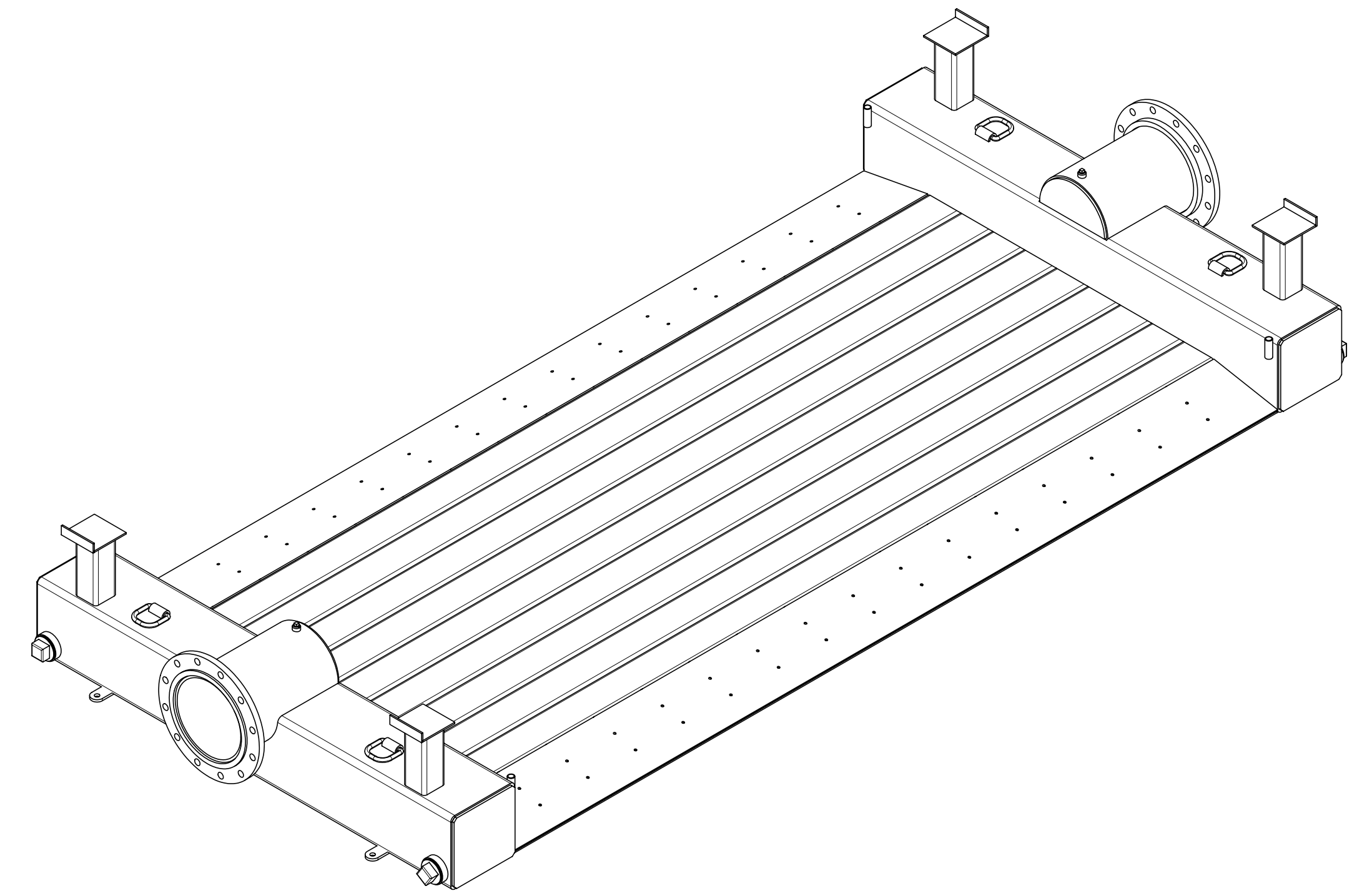
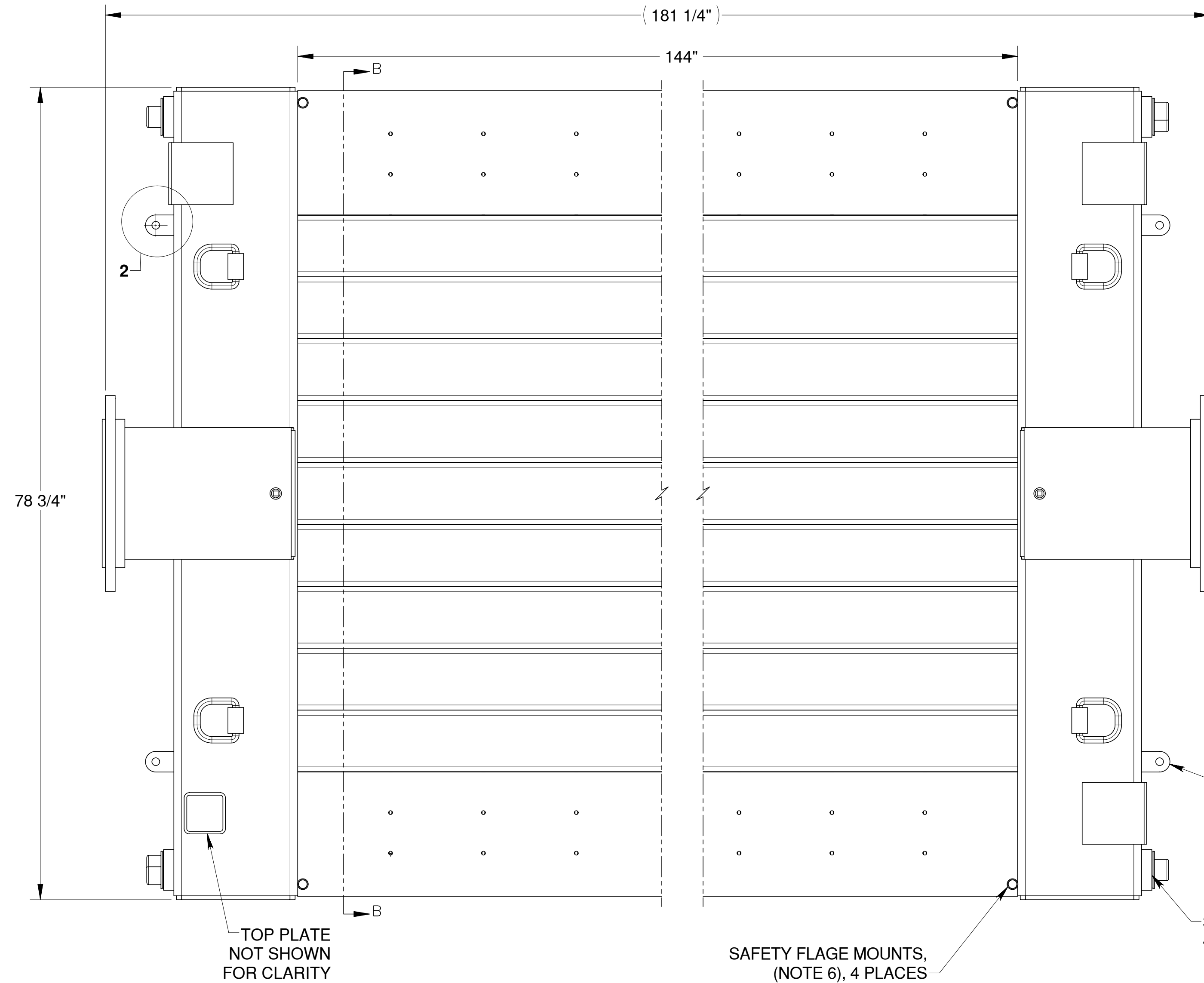

**ISOMETRIC VIEW**  
NOT TO SCALE

**NOTE:**

1. MANUFACTURE GALVANIZE IN ACCORDANCE WITH ASTM A 384 & A 385 STANDARDS.
2. WORKING PRESSURE 75-PSI MAX.
3. MOUNTING POINTS FOR STANDARD SAFETY WARNING FLAGS, (GRAINGER ITEM #4A415, 18" X 18" RED/ORANGE WITH 3/4" DIAMETER DOWEL OR EQUIVALENT), (MANUFACTURE SUPPLY WITH ROAD CROSSING)
4. MANUFACTURE STAMP WEIGHT, APPROXIMATE WEIGHT - 3,000 LBS. EMPTY.
5. ALL WELDS MUST COMPLY WITH AMERICAN WELDING SOCIETY WELD CODE AWS STRUCTURAL D1.1
6. TOUCH-UP WITH ORGANIC ZINK-RICH PAINT COMPLYING WITH MIL-P-21035B OR MIL-P-26915C IN MULTIPLE COATS.

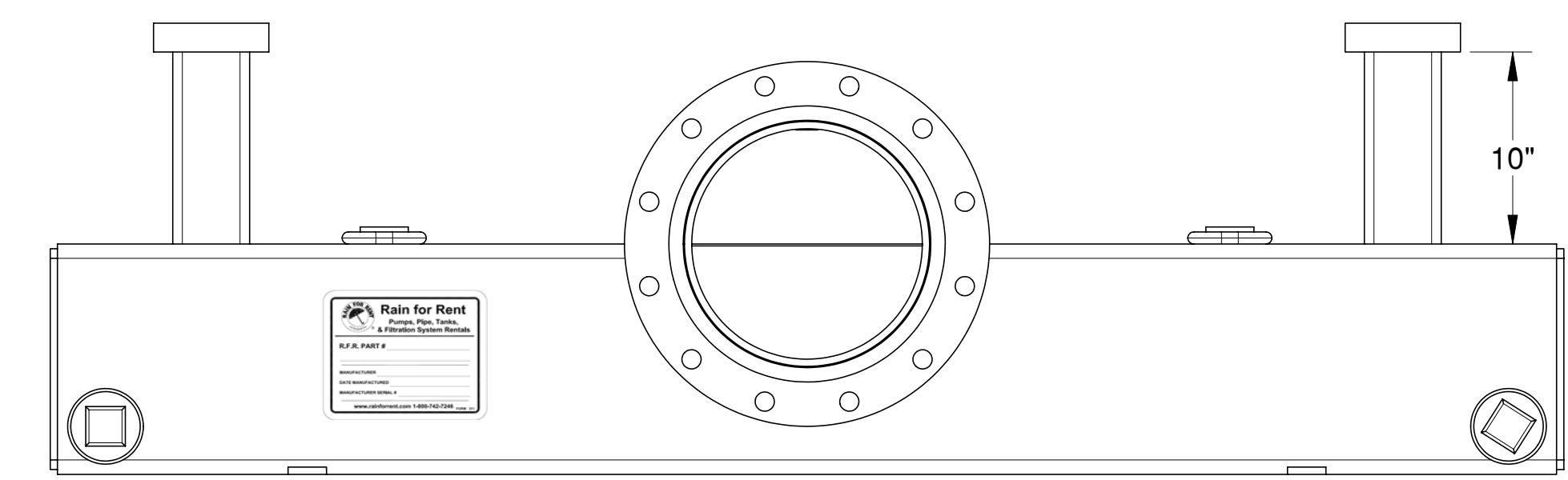
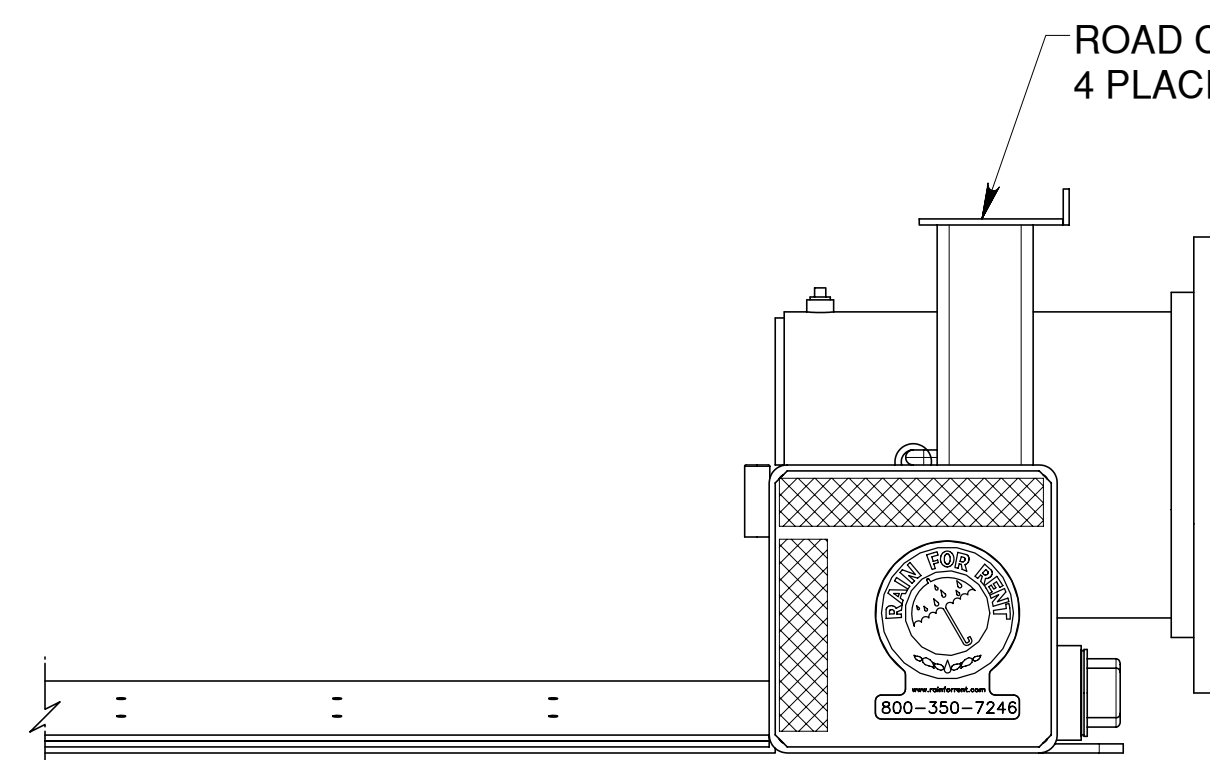
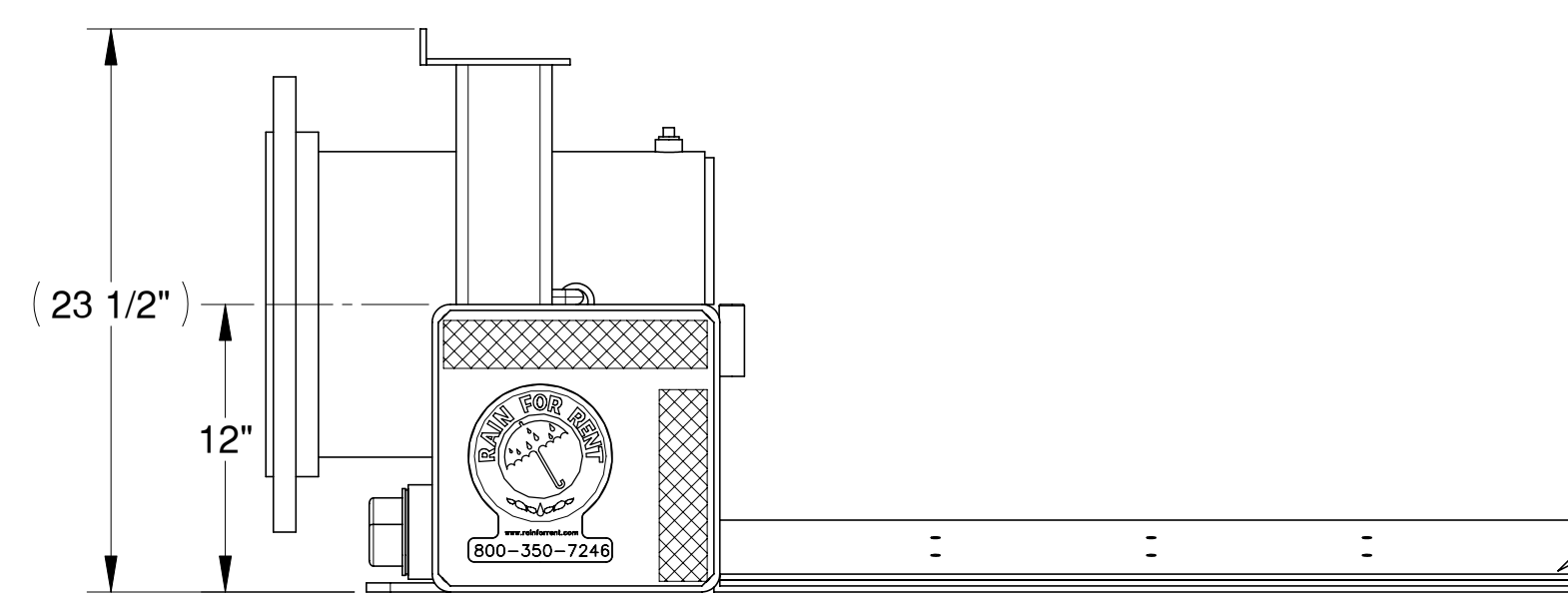

REV. NO.	DESCRIPTION	PREV. DWG	BY	DATE
3	ADDED NOTES AND CHANGED 1/4X12X12 END CAPS TO 3/8X12X12	103011-1_2	MS	3/24/2004
2	CHANGED 1/4" WALL ON 12X12 TUBE TO 3/8" WALL	103011-1_2	MS	3/23/2004
1	CHANGED OVERALL DESIGN	103011-1_2	MS	12/11/2003

UNLESS OTHERWISE SPECIFIED  
 INTERPRET PER ASME Y14.24  
 AND Y14.34M, Y14.35M  
 ALL DIMENSIONS ARE IN INCHES.  
 DIMENSIONS BEFORE PLATING  
 MACHINED FILLET RADIUS TO BE .020  
 SHEET SCALE IS AS LISTED IN TITLE  
 BLOCK, UNLESS SPECIFIED  
 OTHERWISE  
 FRACTIONAL: 1/8  
 DECIMALS: .010  
 .XXX = ±.030  
 .X = ±.100  
 ANGLES: 45°, 30°

**12" X 12' ROAD CROSSING**  
**SALES / REFERENCE DRAWING**

**Rain For Rent**  
 Engineering  
 3404 State Road PO Box 2248 Bakersfield CA 93303

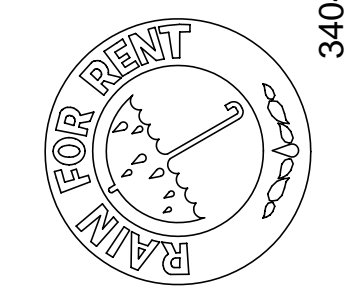

ALL INFORMATION CONTAINED IN OR DISCLOSED BY THIS DOCUMENT IS CONSIDERED CONFIDENTIAL AND PROPRIETARY BY RAIN FOR RENT. ALL DISCLOSURES OF DESIGN INFORMATION AND REPRODUCTION OF THIS DOCUMENT AND ALL SALES RIGHTS ARE EXCLUSIVELY RESERVED BY AND TO RAIN FOR RENT AND COMMUNICATION OF THIS INFORMATION TO OTHERS IS PROHIBITED WITHOUT THE PRIOR WRITTEN CONSENT OF RAIN FOR RENT.

DATE: 10/20/2003  
 SCALE: 1:8  
 DESIGNED BY: K.KROSS  
 CHECKED BY: K.KROSS  
 DRAWN BY: M.STEVENSON  
 JOB NUMBER: 1021213  
 DRAWING NUMBER: 103011-1\_2  
 SHEET: 1 OF 1  
 SHT. SIZE: REV. NO. D 3