

DETAIL 2
SCALE 1 : 4
4 PLACES

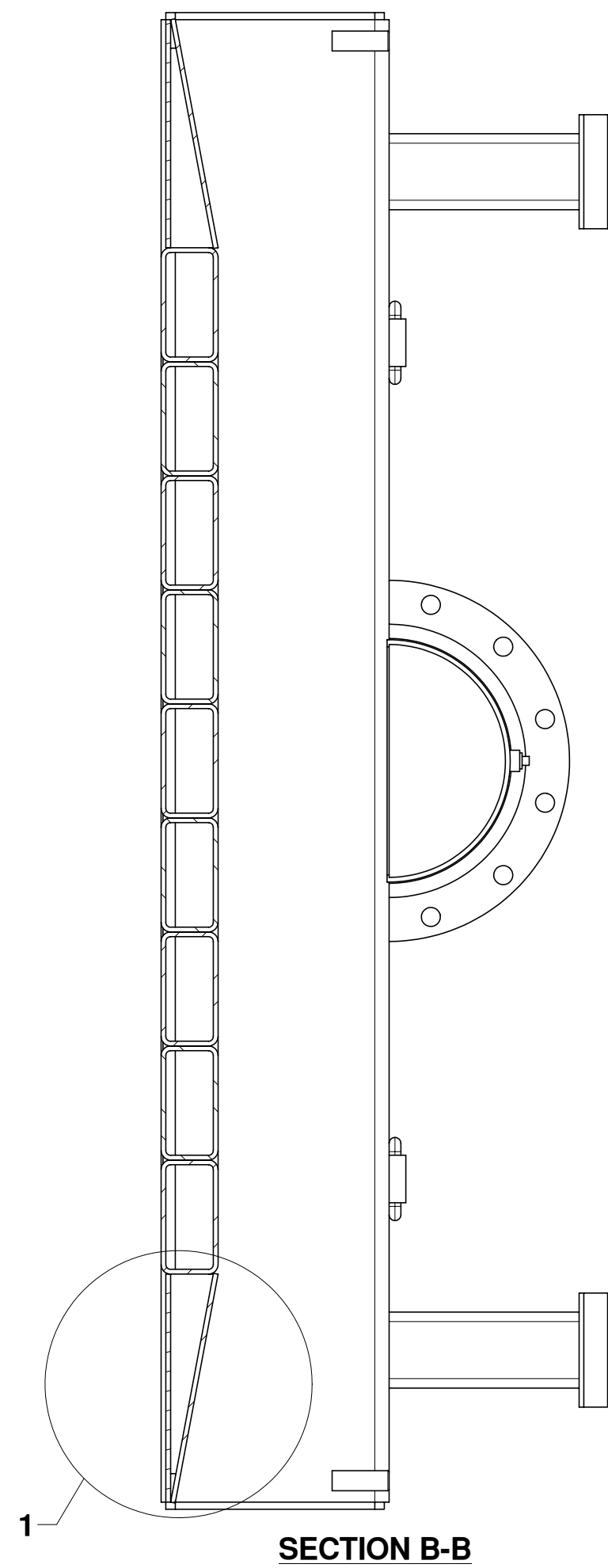

SECTION B-B

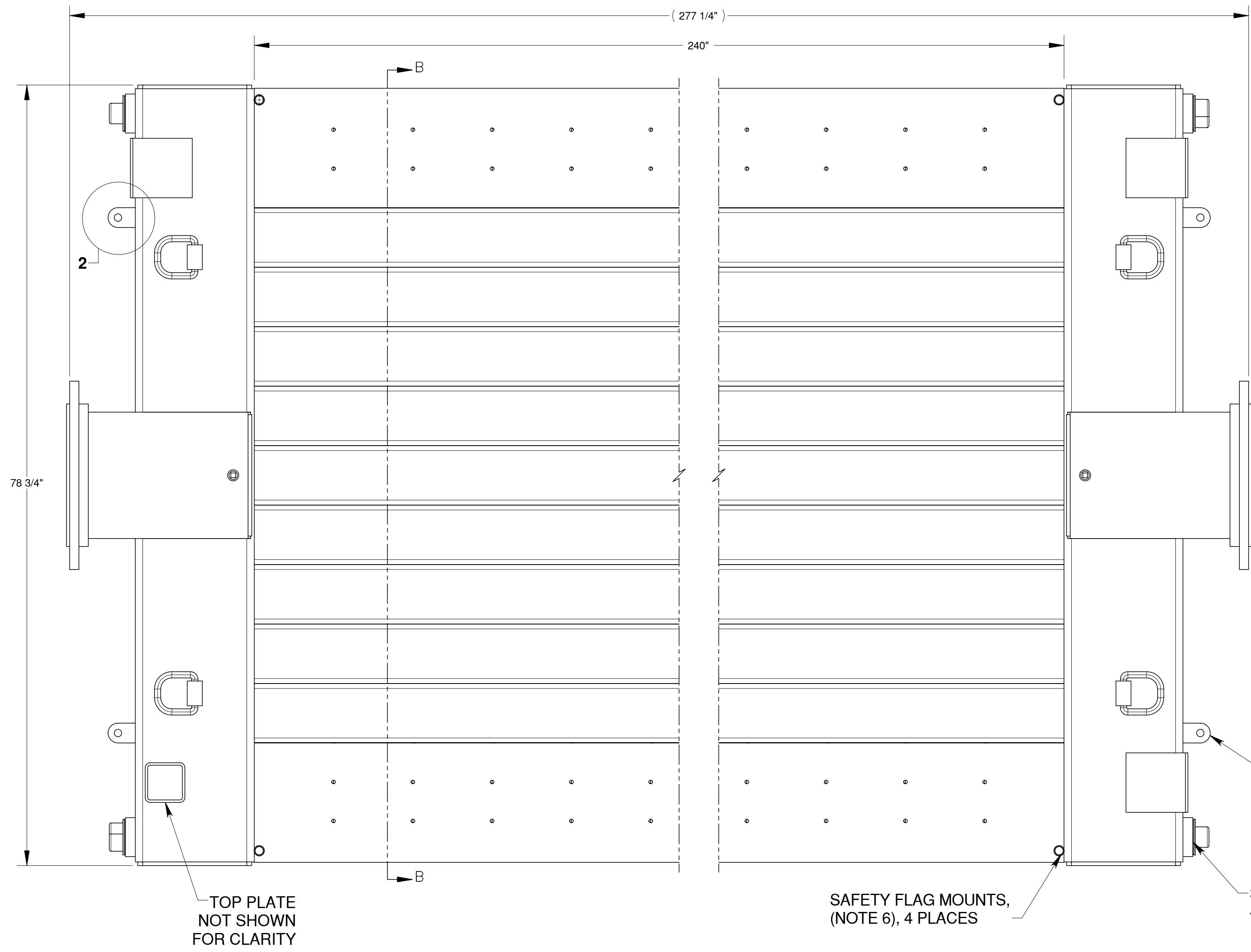

TOP PLATE
NOT SHOWN
FOR CLARITY

SAFETY FLAG MOUNTS,
(NOTE 6), 4 PLACES

ROAD WAY
NAIL/TIE DOWN
4 PLACES
(DETAIL 2)

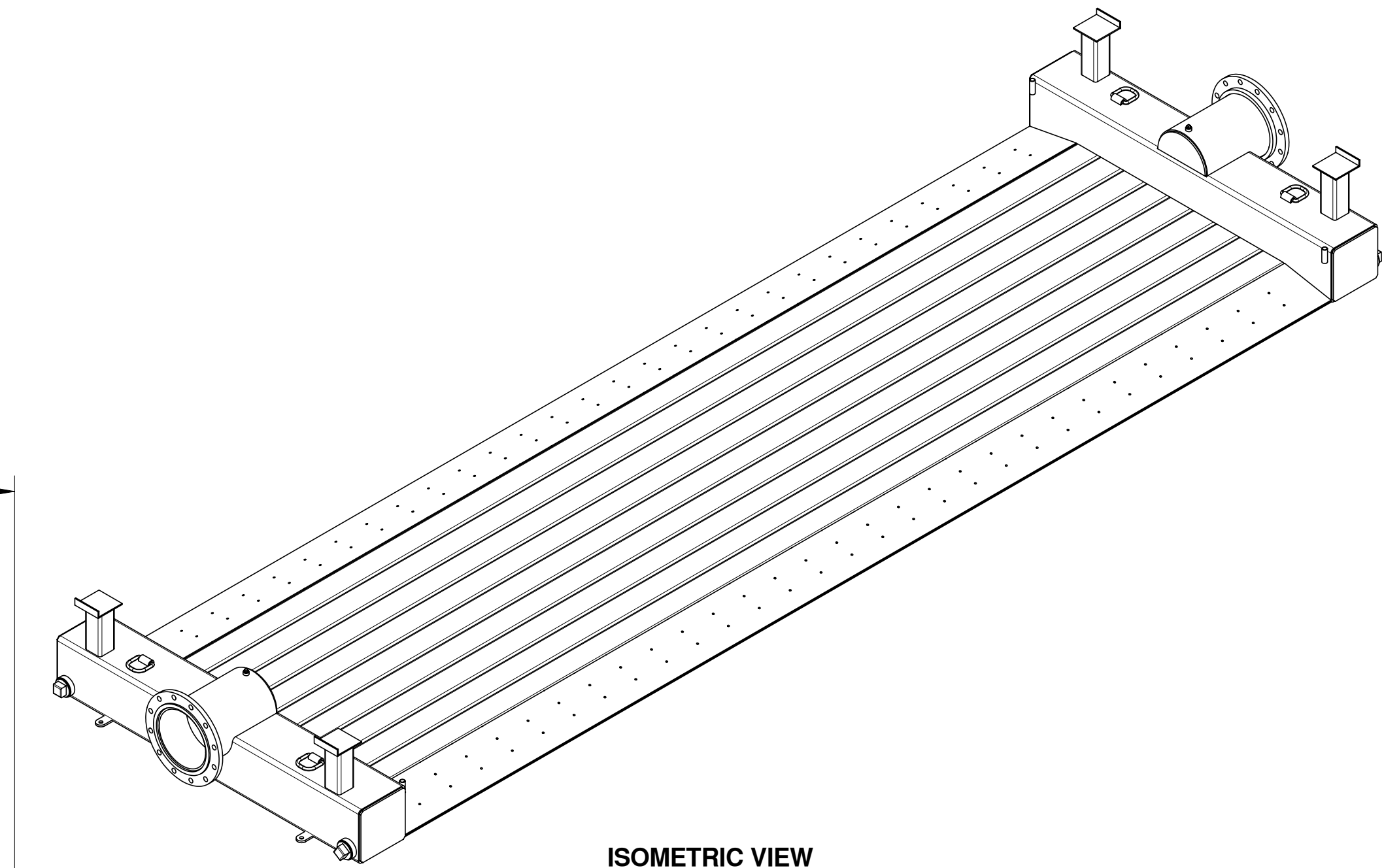

ISOMETRIC VIEW
NOT TO SCALE

- NOTE:**
1. MANUFACTURE GALVANIZE IN ACCORDANCE WITH ASTM A 384 & A 385 STANDARDS.
 2. WORKING PRESSURE 75-PSI MAX.
 3. MOUNTING POINTS FOR STANDARD SAFETY WARNING FLAGS, (GRAINGER ITEM #4A415, 18" X 18" RED/ORANGE WITH 3/4" DIAMETER DOWEL OR EQUIVALENT), (MANUFACTURE SUPPLY WITH ROAD CROSSING)
 4. MANUFACTURE STAMP WEIGHT, APPROXIMATE WEIGHT - 4,100 LBS. EMPTY.
 5. ALL WELDS MUST COMPLY WITH AMERICAN WELDING SOCIETY WELD CODE AWS STRUCTURAL D1.1
 6. TOUCH-UP WITH ORGANIC ZINK-RICH PAINT COMPLYING WITH MIL-P-21035B OR MIL-P-26915C IN MULTIPLE COATS.

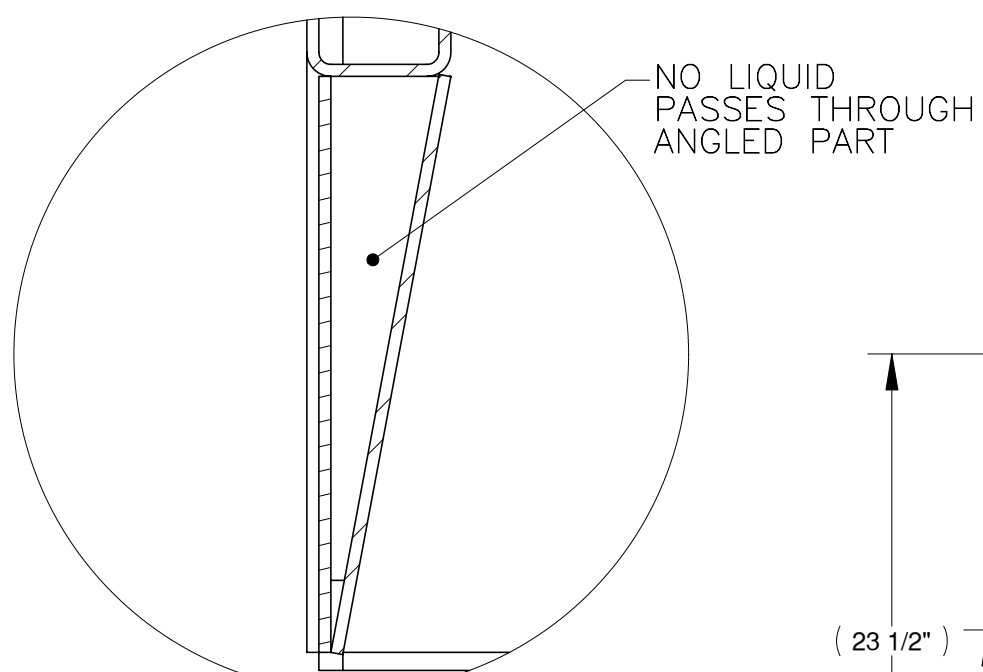

DETAIL 1
SCALE 1 : 4
ANGLE/FLAT BAR WELDMENT

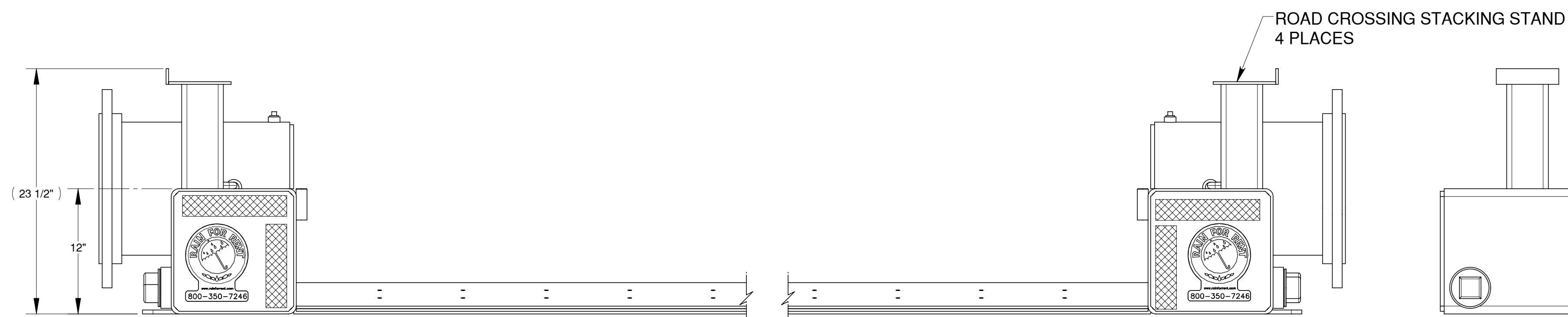

ROAD CROSSING STACKING STAND
4 PLACES

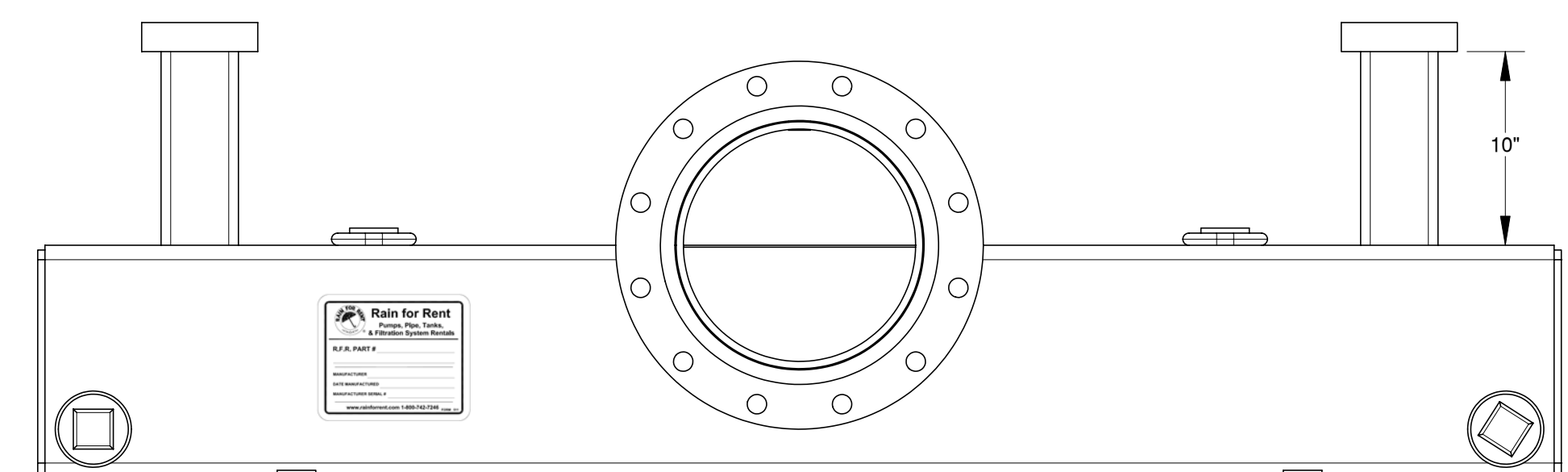

REV. NO.	DESCRIPTION	DATE	BY	DATE
1	ADDED STAKING LEGS	103011-1_3	MS	5/5/2005
		PREV.DWG		

12" X 20' ROAD CROSSING

SALES / REFERENCE DRAWING

Rain For Rent
Engineering

3404 State Road PO Box 2248 Bakersfield CA 93303

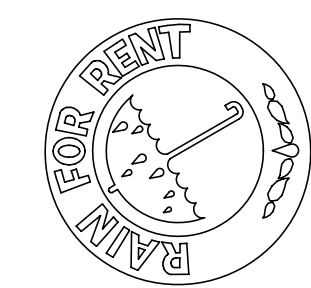

ALL INFORMATION CONTAINED IN OR DISCLOSED BY THIS DOCUMENT IS CONSIDERED CONFIDENTIAL AND PROPRIETARY BY RAIN FOR RENT. ALL DISCLOSURES OF DESIGN INFORMATION AND REPRODUCTION OF THIS DOCUMENT AND ALL SALES RIGHTS ARE EXCLUSIVELY RESERVED BY AND TO RAIN FOR RENT AND COMMUNICATION OF THIS INFORMATION TO OTHERS IS PROHIBITED WITHOUT THE PRIOR WRITTEN CONSENT OF RAIN FOR RENT.

DATE	SCALE
10/20/2003	1:8
DESIGNED BY	K.KROSS
CHECKED BY	K.KROSS
DRAWN BY	M.STEVENSON
JOB NUMBER	1021213
DRAWING NUMBER	103011-1_3
SHEET	1 OF 1
SHT. SIZE	REV. NO.
D	1